

SOLAR STREETLIGHT



ENGO ALL-IN-ONE

Cost effective solution for:



Powered by the sun



Environmental Sensors



High Quality Lithium
Battery



Easy and Fast installation



Motion Sensors



Remote Management

- ▶ Parks
- ▶ Parking Lots
- ▶ Industrial Facilities
- ▶ Trails & Pathways
- ▶ Security Perimeters
- ▶ Bicycle Lanes
- ▶ Rural areas
- ▶ University Campuses

EnGo All-In-One is a reliable and cost-effective solar-powered street light solution that will illuminate a wide range of applications, from roads in rural areas to many places in urban communities. Our solar solutions provide a high level of lighting output with more than 160 lumens per watt which enabled us to create a product that will incorporate all components into one compact and modern design.

EnGo All-In-One will increase visibility and security for everyone (pedestrians, cyclists, children, secondary road users, refugee camps, communities, businesses, markets etc.) without the need for grid connection. In addition, this smart solution also can be used to power optional features such as **WiFi Internet connectivity and CCTV Camera**.



High Quality components

Solar Panel

Lithium Battery

MPPT Controller

IP 66 Die Casting Aluminum Housing

LED Light

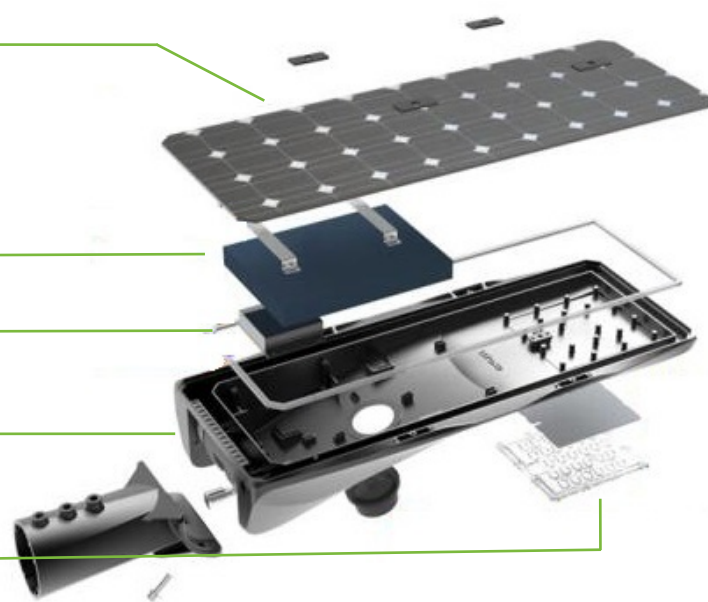

Battery:	Lithium 40 Ah.12V	Lithium 50 Ah.12V
Beam angle:	150x70	150x70
Pole diameter:	60 mm	60 mm
Light output:	20W	30W
Luminous flux(lm):	3200 lm	4800 lm
Color Temperature:	2700-6500K	2700-6500K
CRI:	>80	>80
LED Chip Brand:	LUXEON 5050	LUXEON 5050
Lifespan (hrs):	>50000	>50000
Solar Panel Wp:	50 wp	50 wp
Housing:	Die Casting Alu	Die Casting Alu
IP Rating:	IP 66	IP 66
Installation height	3-5m	4-6m

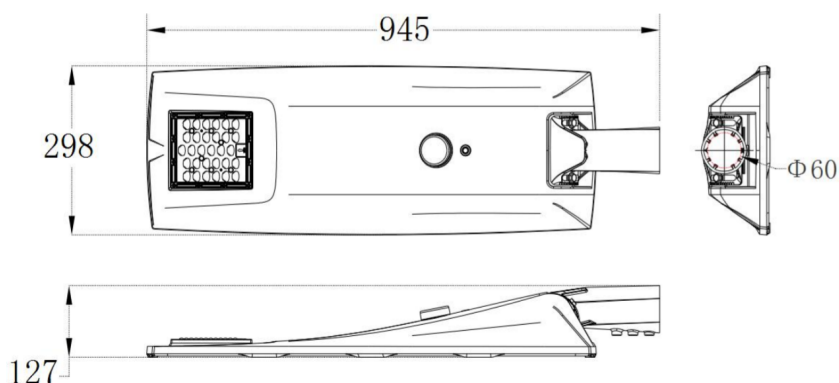

Dimensions:	945x298x127
Net Weight (kg)	10 kg
Package Size (mm)	1000*340*180
Package quantities (pcs)	1
Gross Weight (kg)	11.1 kg