



Type 23B/3C

High power capability base mounted marine HF whip antenna for military and professional vessels over 18 metres (60 feet)

The type 23B/3C is a 7 metre (23 ft) heavy duty self supporting whip antenna with a continuous power capability up to 1 kW in the frequency range 1.6 to 30 MHz. It is designed to provide efficient and reliable communications in the professional and military services. NATO No. 5985/66/129/1426.

The 23B/3C is base mounted and designed to withstand constant wind speeds up to 250 km/h (156 mph) without permanent deformation effects. Construction is of heavy gauge marine grade aluminium alloy tubing to give a large low loss surface area for maximum radiating efficiency, fully protected by a high durability epoxy based coating resistant to chemical attack, abrasion and the effects of ozone and ultra-violet radiation.

A high reliability corona shield forming part of the base insulator reduces the effects of flashover caused by saltwater spray and permits a rapid recovery from saltwater induced short circuits caused by splashing. The shield neither burns nor leaves tracks, even when subject to severe surface arcing, and is impact resistant, being moulded onto the antenna using a flexible modified polymer. The physical shape of the shield is arranged to provide a long and broken path to further assist with low leakage of RF energy.

For ease of transport, the antenna breaks down into two sections [base 3.76m (12.3 ft); top 3.35m (11 ft)] which slip together and fasten with four stainless steel locking screws.

Specifications

Colour	Standard is APO Grey
HF Marine Band	1.6-30 MHz
Length	7.0 metres (23 ft)
Pattern	Omnidirectional
Polarisation	Vertical
Frequency Range	Unloaded 1.6-30 MHz with suitable ATU
Wind Loading	8.8 kg at 100 km/h (19.5 lbs at 60 mph); 20 kg at 150 km/h (44 lbs at 94 mph); Antenna survival : 250 km/h (156 mph)
Power Capability	Up to 1 kW continuous
Base Insulator	>25 kV insulator flash over voltage (test conditions: antenna dry)
Radiator	Total radiating surface: 5,500 sq cm (5.9 sq ft)
Mountings	Cast aluminium alloy base flange and support tube with integral base insulator, O ring seal and corona shield, silicone joint shroud
Base Mount Finish	Epoxy based enamel
Connection	M6 stainless steel stud and lock nuts direct to antenna
Packed Weight	20 kg (44 lbs) with mountings Antenna and base unpacked 10 kg (22 lbs)

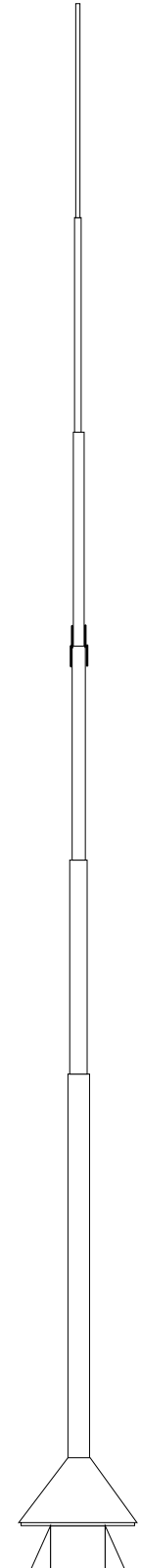

Specifications subject to change – Issued 07/13

Moonraker Australia Pty. Ltd. ABN 70 162 868 475
Tasmanian Technopark, Dowsing Point, Tasmania, Australia 7010

Website: www.moonraker.com.au Tel: 61 (0)3 6273 1533 Fax: 61 (0)3 6273 1749 Email: radiocom@moonraker.com.au





23B/3C INSTALLATION INSTRUCTIONS

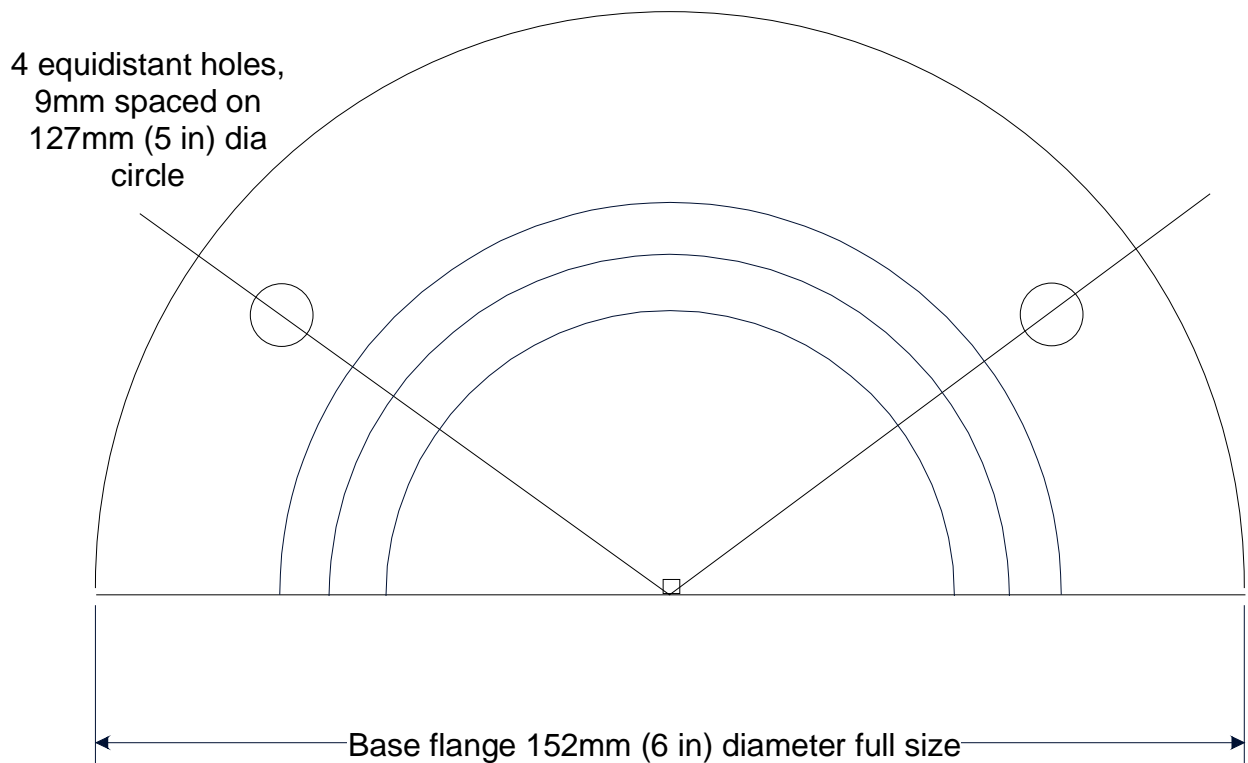

Assembly

1. For ease of maintenance lightly smear the antenna middle joint with grease and push firmly together. Place silicone sealant on screw thread before screwing into place.
2. Tighten screws firmly and cover heads with sealant.
3. Drill four 8 mm (5/16 ins) clearance holes to suit base mount in position required. Erect the aerial and bolt down using 8mm (5/16 ins) S/S bolts.
4. Use sealant on underside of mount and on bolts to prevent ingress of moisture.

Connection

Connecting wire from tuning unit to aerial should be not less than 7/1.04 hard drawn insulated copper cable. It should be run well clear of metal objects and be as short and direct as possible. Cover the connections liberally with silicone sealant. We recommend the use of Moonraker feedthrough and standoff insulators for this antenna.

N.B. Sealant should be non-acid neutral cure type. Acid cure type sealant will attack copper and aluminium.



Specifications subject to change – Issued 07/13

Moonraker Australia Pty. Ltd. ABN 70 162 868 475
Tasmanian Technopark, Dowsing Point, Tasmania, Australia 7010

Website: www.moonraker.com.au Tel: 61 (0)3 6273 1533 Fax: 61 (0)3 6273 1749 Email: radiocom@moonraker.com.au

