

DAISY BELL TECHNICAL RIDER & STAGE PLAN

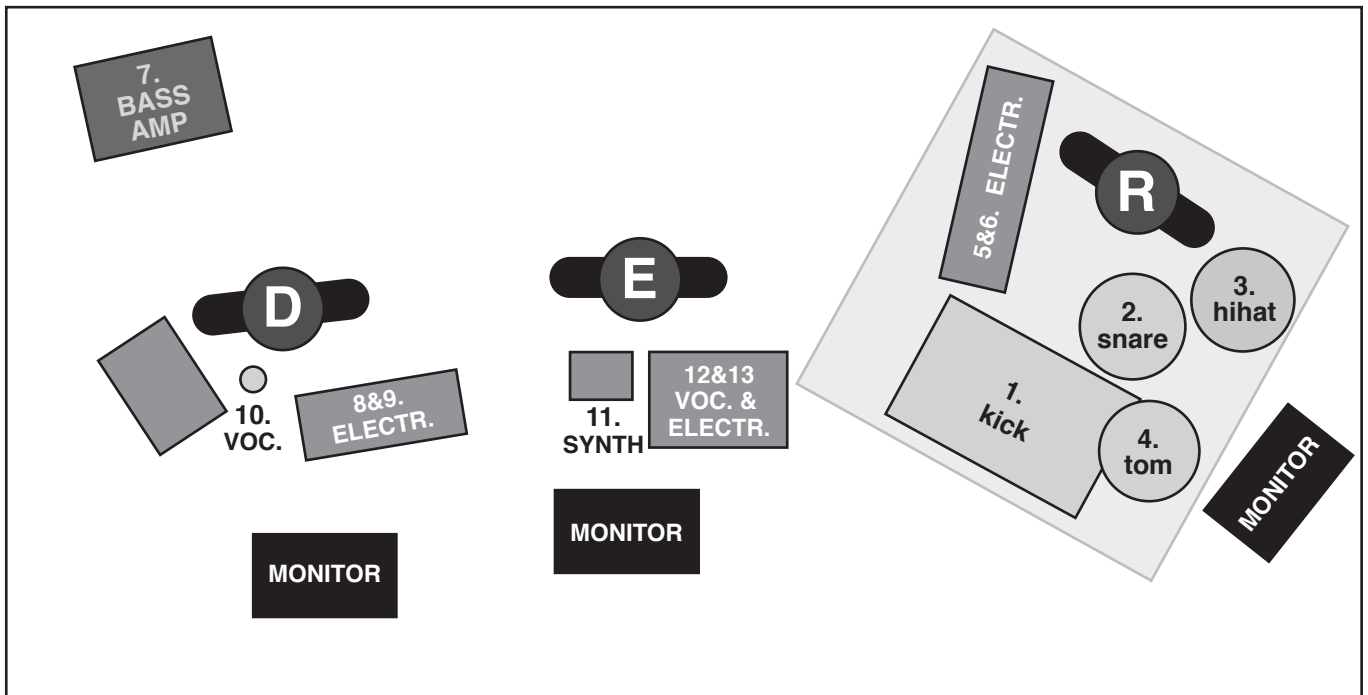

CHANNEL LIST:

1. KICK - Heil PR40 / Sennheiser SM52 Beta
2. SNARE - (top) Beyer Dynamic M201 / Shure SM57
3. HIHAT - Oktava MK-012 / Røde NT5
4. TOM - Sennheiser MD412
5. RICHARD ELECTRONICS L. } XLR balanced outputs from Richard's mixer
6. RICHARD ELECTRONICS R. }
7. DYANE BASS GUITAR - (Fender Amp)
8. DYANE ELECTRONICS & GUITAR L. } Outputs 1&2 (Jack) from Dyane's audio interface
9. DYANE ELECTRONICS & GUITAR R. }
10. DYANE VOCALS - Sennheiser e945
11. EVELIEN MONOTRIBE SYNTH - Jack out to D.I. Box
12. EVELIEN VOCALS & FX L. } Outputs 1&2 (Jack) from Evelien's audio interface
13. EVELIEN VOCALS & FX R. }

NOTE!: ALL BACKLINE & MICROPHONES SUPPLIED BY DAISY BELL

NEEDED FROM VENUE: - 3 X MONITOR
- 5 X D.I.BOX
- F.O.H. MIXER + P.A.
- REVERB EFFECT UNIT

BUILD UP TIME: 60 MIN.
SOUNDCHECK TIME: 30 MIN.
MINIMUM STAGE REQUIRED: 12 M²

CONTACT:
info@daisybell.eu
+31 (0)6 5495 8761