

PLAN VIEW

- NOTES:
1. STATION REQUIRES 120 VOLT, 5 AMP DEDICATED CIRCUIT (PROVIDED BY OTHERS).
 2. TWO 7/8" DIA. HOLES IN TOP OF STATION FOR ONE CONDUIT CONNECTION AND ONE COMMUNICATION CABLE CONNECTION.
 3. STATION TO BE FLOOR MOUNTED.
 4. LEG BRACKETS ARE IN 2" INCREMENTS.
* VERIFY WITH OWNER ANY MILLWORK THAT MIGHT INTERFERE WITH STATION HEIGHT.
 5. RECOMMENDED CONTROL PANEL HEIGHT IS 5'0".
 6. ROUGH OPENING IS 22" x 33".
 7. STATION WEIGHT IS 132 LBS.

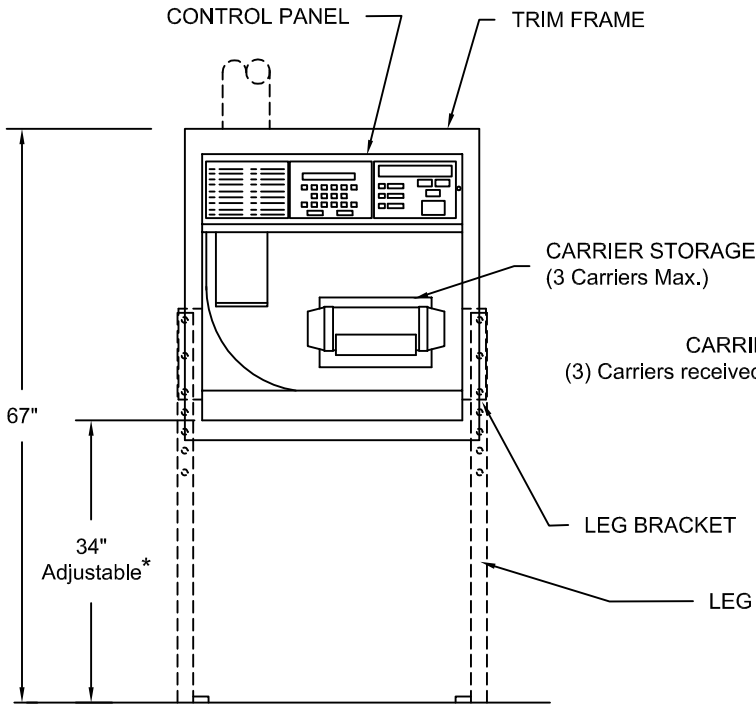

FRONT VIEW

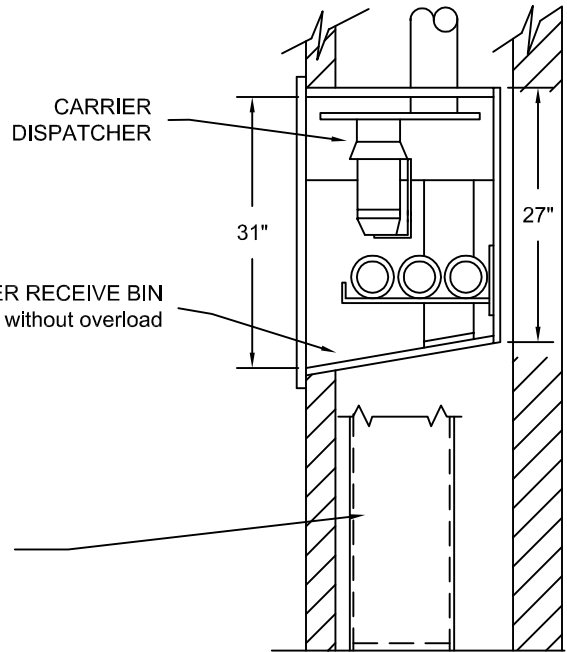

SIDE SECTION

Pevco™

Baltimore, Maryland
800.296.PEVCO (7382)
WWW.PEVCO.COM

**WALL RECESSED
STANDARD (1-PORT) STATION**

6" COMPUTERIZED PNEUMATIC TUBE SYSTEMS

SCALE	NONE	DATE
DRAWN	SDW	05.01.00
REVISED	SDW	01.06.06
	SDW	10.22.07
DRAWING NUMBER	PEV200.2	REVISION 4